

# Considerations for the use of the Depressed Collector IOT in digital and analog TV service

**Andy Whiteside**

Ai

10706 Beaver Dam Road  
Cockeysville, MD 21030  
andy.whiteside@acrodyne.com

**Ray Kiesel**

Ai

10706 Beaver Dam Road  
Cockeysville, MD 21030  
ray.kiesel@acrodyne.com

**Jay Gamerman**

Ai

10706 Beaver Dam Road  
Cockeysville, MD 21030  
jay.gamerman@acrodyne.com

## Abstract

*There have been a number of articles and papers in the past 12 months extolling the virtues of the new breed of IOT, the multi-stage depressed collector IOT, in digital TV service. The performance and benefits of this hybrid device, a combination of two proven technologies, in digital service are certainly impressive but little, if any, consideration has been given to its use in analog TV service. Such application as has been mentioned has minimized the potential benefits to the U.S. broadcaster. This article will show that the new technology can, in fact, be applied to analog transmission with immediate financial benefits to the broadcaster – especially those broadcasters using old klystron transmitters.*

## Keywords

MSDC IOT, ESCIOT, Depressed Collector, Inductive Output Tube, UHF TV Transmitter, Television.

## THE CURRENT SITUATION IN THE USA

The future of broadcast TV is digital - but the future is not yet here. Presently, U.S. broadcasters rely almost exclusively on their analog signal for revenue. Even though there are a considerable number of operational digital TV stations, very few, if any, have managed to convert their significant investment into a source of any revenue. In fact, many broadcasters are taking another look at their analog transmission plant to ensure that the engine for their major revenue stream will be viable for what now appears to be an indeterminate number of years. In many cases, that analog transmission plant is aging, using old technology that is costly to operate in terms of both power consumption and maintenance. In addition, spare parts are most likely becoming increasingly difficult and costly to obtain. Also, the older transmitters lack modern safety features, perhaps exposing station personnel to unsafe conditions and the station itself to considerable liability.

Most of the development effort in the transmitter field in the past 10 years has been geared toward digital transmission products. This has resulted in significant advances in transmitter technology in the areas of pre-correction, control and monitoring, solid-state amplification and high power linear amplification, to name a few. There is no fundamental reason that these advances can not be applied to analog transmission – offering immediate benefits to the U.S. broadcaster in terms of reduced power cost, improved reliability, reduced maintenance costs, increased building space and enhanced safety. In some cases the payback on the in-

vestment in new plant can be less than 5 years just from the power savings alone. When one considers that there are several hundred stations that still need to build out full power digital facilities, these new analog transmitters offer an added benefit in that they can be readily converted to digital service at the appropriate time.

## RECENT DEVELOPMENTS IN TRANSMITTERS

Since the introduction of the IOT led to Common Amplification becoming the dominant mode of amplification in broadcast transmitters in the early 1990s, transmitter configurations have become remarkably similar. One or more exciters drive one or more high power amplifiers. The signal is then combined and filtered before passing through the transmission line on to the antenna. It is clearly desirable to have minimal differences between a transmitter system optimized for analog service and one optimized for digital service. This will give the broadcaster maximum flexibility to accommodate future requirements – whatever they may be and whenever they may occur. The goal of the transmitter manufacturer becomes the design of a transmitter that truly does minimize the differences between the two services.

The design of a high power UHF TV transmitter is so strongly influenced by the choice of final amplifier device, that the selection of that device can become the determining factor in achieving the goal discussed above. For the past 10 years or so, the IOT has been the dominant choice as the final amplifier in high power UHF transmitters. It is ideally suited to amplify signals of any TV format. The new range of high power IOT transmitters adds the field proven energy saving feature of collector depression to the already efficient IOT mode of operation. There are several depressed collector IOTs available from the major tube suppliers – with differing numbers of depressed stages and cooling methods. It appears that the best compromise between efficiency enhancement and practical collector manufacture results from collectors with 5 individual stages – as was the case with the MSDC klystron.

Most of the development and implementation effort in the field of depressed collector IOT transmitters has been focused on DTV performance. In fact, the first installed transmitters using this technology operate in the DTV mode. As it has become clear that analog TV still has a primary role to play in station profits, some manufacturers have focused on the performance of these new devices in analog service. It now appears that not all depressed collec-

tor IOTs have the capability of providing digital **and** analog output powers equal to their non-depressed equivalents.

**POWER CAPABILITY**

The power level of the typical IOT transmitter HPA building block is 25 to 30 kW average in DTV service and 60 to 70 kW peak sync in Analog service. These power levels have been available for several years from conventional IOT devices. In fact, the IOT elements, such as the electron gun, and physical structure had primarily been designed for the demands of analog service and they proved to be more than adequate for digital applications. Reversing this approach and optimizing the IOT elements for digital service will likely result in a compromise in analog capability.

As should be obvious, the collector structure is the defining difference between the conventional and depressed collector IOT. The principle function of any collector, depressed or otherwise, is to dissipate the spent energy of the electron beam, in an efficient and safe manner, under all signal conditions. Since the “spent” electron beam has a distribution of energies, the use of multiple collector stages at discrete and different depression voltages with respect to ground can “sort” the electrons by energy and recover a significant percentage of the beam energy – hence reducing power consumption. The nature of the signal being amplified in the IOT, as well as the actual power level, determines both the total dissipation and, equally as important, the distribution of that dissipation over the collector surface. The DTV signal leads to a fairly well defined, and effectively static, distribution over the collector internal surfaces, at a given power output, (ref 1). It is, therefore, possible to select the collector depression voltages to distribute the spent beam relatively evenly, in terms of electron current, thus reducing the average power density and making the job of the cooling liquid that much easier. If a collector is designed for these static DTV currents it may not be suitable for analog service.

The NTSC signal is amplitude modulated and the energy spread in the spent beam will be significantly different at different picture levels. This is modified somewhat when the IOT is used in the common amplification mode due to the constant presence of the CW Aural signal, but the effect must be taken into account in the design of the collector, the cooling system and the HV power supply. As an illustration, consider the following results from a 5 stage depressed collector IOT under digital and analog signal conditions. (Collector 1 is at Ground potential and the other Collectors are increasingly more negative with respect to Ground).

**Chart 1 – Collector Current comparison**

Parameter	Digital @ 30kW	Analog @ 60/6 kW	
	Constant	White APL	Black APL
C1 current	180 mA	100 mA	178 mA
C2 current	0.5 A	0.25 A	0.83 A
C3 current	0.5 A	0.35 A	0.80 A
C4 current	1.1 A	1.05 A	0.94 A
C5 current	1 mA	0.4 mA	0.2 mA

Total current	2.28 A	1.75 A	2.75 A
---------------	--------	--------	--------

As one can see from the chart, the current amplitudes on the different collector stages vary with the picture level. Since the IOT designer and transmitter designer do not control the picture level, the product design for analog operation must handle extended operation at the extremes of the range. A side benefit of meeting this requirement is that operation in the digital mode is easily accommodated.

Consider the consequences of a transmitter designed with maximum ratings based on the current readings in the “Digital @ 30kW” column above. To ensure that the ratings are not exceeded in analog service, the maximum power rating of the IOT and transmitter must be reduced significantly – well below that of the non-depressed collector IOT equivalent, rendering it unsuitable for this service.

In summary, the proven principle of designing for the worst case, in this case analog, should be followed in designing a true dual use transmitter that will have immediate and future benefit to the U.S. broadcaster.

**COLLECTOR COOLING**

In general, it can be said that higher power dissipations on a given collector stage require more mass of material in order to ensure that the collector and the coolant stay at reasonable and safe operating temperatures. As discussed in the previous paragraphs, the analog signal results in the requirement of greater power dissipation capacity on several of the collector stages. In order to handle this increased dissipation, the tube designer prefers to have the freedom to size the collector elements and coolant jacket without unnecessary constraints. This can only be realized if the collector does not have to pass through the focusing magnet structure during installation - this almost certainly explains why 3 of the 4 IOT manufacturers have designed depressed collectors on their plug-in style of IOT. The collector is on top of the IOT in such designs – see photograph 1 – and the tube designer is free to change the size of the collector without the concern of affecting the amplifying part of the IOT. There are a number of advantages in using the plug-in style IOT, separate from those associated with the collector design, and there has been a trend towards using this type of IOT in new transmitters in recent years.



**Photograph 1 – The e2v ESCIOT installed in the Ai Quantum HPA**

coolants and it is widely available. It is historically the standard choice of tube and transmitter designers and it provides the benchmark against which other coolants must be measured. The dielectric isolation is easily provided by the incorporation of a de-ionizing loop and freeze protection can be designed into the cooling system. Many millions of operating hours have been accumulated using de-ionized water in high power transmitters worldwide, in a broad variety of environmental conditions. Of significance is the fact that all MSDC klystrons use de-ionized water, (ref 1). The analysis of the lives of these devices indicates that the average life is higher than their non-depressed klystron brethren. There could be a number of reasons for this fact, but it is generally accepted that the use of pure water is a major contributor to the extended lives.

An added advantage of using de-ionized water is that this coolant can also be used to cool the other elements of the IOT and cavity, thus affording the transmitter designer the opportunity to eliminate glycol from the IOT High Power Amplifier (HPA) cabinet entirely – greatly simplifying the cabinet cooling system as shown in diagram 1 below. Many of us have had to deal with the consequences of coolant spills or leaks in transmitter cabinets at some time or other. Cleaning up water is a lot simpler and quicker than cleaning up glycol, oil or other coolants!

**THE ECONOMICS OF THE DEPRESSED COLLECTOR IOT**

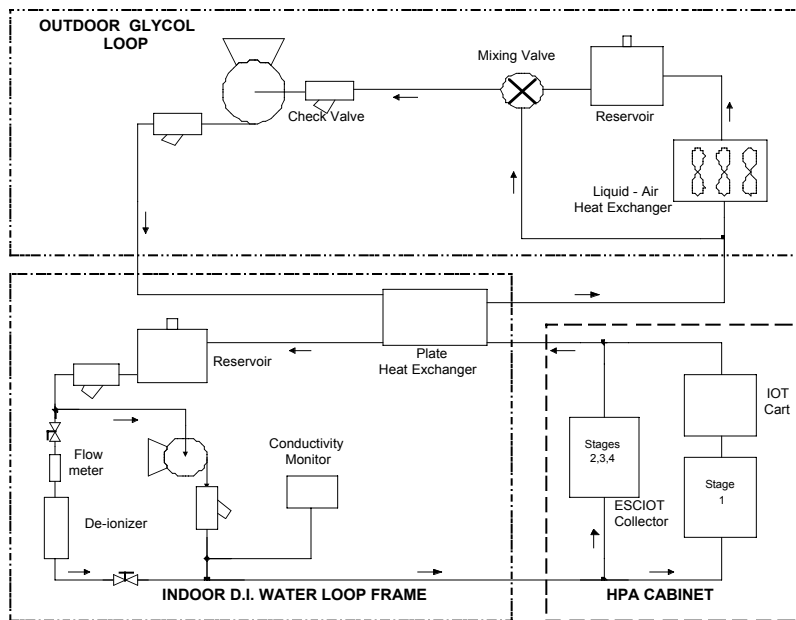

**Diagram 1 – Simplified QDC Cooling diagram**

Given that the collector stages can be sized appropriately in the plug-in IOT, the selection of an appropriate coolant becomes relatively straightforward. It goes without saying that the coolant must provide good dielectric isolation between stages, as well as allowing efficient heat transfer from the collector and transport of the heated coolant to the heat exchanger. Water is by far the best coolant for use in cooling high power vacuum tubes. It has the highest specific heat capacity and thermal conductivity of available

The above discussion points are background to the real point of the depressed collector, i.e. reducing power costs for the broadcaster and thus enhancing profits. The data shown in Chart 2 is typical of the performance of the e2v ESCIOT 5130W (ESCIOT = Energy Saving Collector IOT) - a 5 stage depressed collector IOT – in an Ai Quantum transmitter.

**Chart 2 – ESCIOT vs. standard IOT Performance**

	DTV	NTSC
Transmitter Output	60 kW avg.	120+12 kW
IOT Output – includes RF Losses	66 kW avg.	130/13 kW
Quantity of IOTs	2	2
Standard IOT efficiency <sup>2</sup> /FOM <sup>3</sup>	38 %	100 %
ESCIOT efficiency/FOM	58 %	149 %
Percentage Improvement	53 %	49 %
Standard IOT Power Consumption	173.1 kW	144.7 kW <sup>1</sup>
ESCIOT Power Consumption	113.4 kW	97.1 kW
Reduction in IOT Power Consumption	59.7 kW	47.6 kW
IOT Percentage Reduction	34.5 %	33 %
Reduction in TX Power Consumption <sup>4</sup>	57.2 kW	45.4 kW
TX Percentage Reduction	28.7%	26.7%
Annual savings at 8 cents/kW-hr <sup>5</sup>	\$40,086	\$31,816

Note 1: The signal level for the NTSC data was 50% APL with 10% Aural

Note 2: The term “efficiency” is used for digital operation. It is equal to average RF output power divided by average DC input power.

Note 3: The term “Figure of Merit” or “FOM” is used for analog operation. It is equal to (peak visual + average aural) divided by average DC input at a defined signal level – 50% APL.

Note 4: The TX (transmitter) power consumption reduction is slightly reduced due to increased losses in the multi-stage HV power supply and the additional consumption of the small pump in the de-ionized water loop for the ESCIOT.

Note 5: Annual savings calculation based upon 8 cents/kW-hr and 24x365 hours per year.

Two things are worth noting from Chart 2. First, this tube is capable of full power operation in digital and analog service. Second, contrary to recent claims from some sources, this depressed collector provides the same percentage reductions in power consumption whether operating in digital or analog mode. In other words, the use of this tube provides a solid start in meeting the earlier stated goal of minimizing product differences between analog and digital operation. Of added interest to the transmitter designer, and the end-user, is the fact that these improvements are obtained by the use of only two additional HV outputs from the HV power supply – since 2 of the 5 ESCIOT collector stages are actually connected to other stages. See diagram 2 for a simplified HV connection schematic.

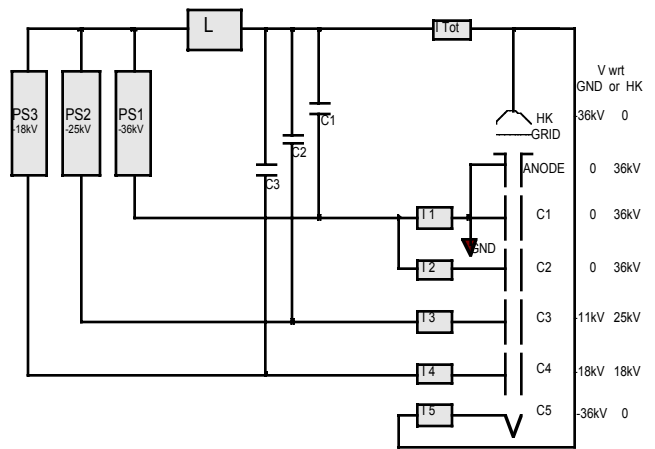

**Diagram 2 – 5 stage ESCIOT HV Interconnect**

Efficiencies equal, or close, to those in Chart 2 can be achieved at lower output powers by matching the tube beam voltage to the required power, in accordance with the tube manufacturer’s recommendations.

From the end-user’s perspective, a significant reduction in power input cost can be factored into budget planning in either mode of operation. Although the HV power supply power consumption is reduced by a third, the overall plant input power will not reach the same reduction. This is because there are two other factors, albeit relatively minor, in the plant consumption that offset the reduction. The multi-stage HV Power supply is a few percent less efficient than a single output HV supply and the consumption of the small pump in the de-ionized water loop must be added. These factors are already taken into account in Chart 2, as is the RF System loss.

**ANALOG PERFORMANCE**

The IOT has only been in widespread use since the early 1990’s. IOT equipped transmitters are still considered relatively new! Such transmitters afforded considerable savings over the replaced transmitters, typically klystron equipped. Although the ESCIOT equipped transmitter does offer 30% lower power consumption than the standard IOT transmitter, it is unlikely that this would be considered sufficient savings to justify the replacement of this relatively new NTSC IOT equipment. However, there are a significant number of aging klystron transmitters still in use, and a review of Chart 3 below will show that the argument for generating savings by replacing these transmitters with new ESCIOT equipped product is quite compelling.

**Chart 3 – 120kW NTSC Transmitter Comparison**

Type	NTSC at 120/12 kW output, 50%APL	
	Standard Klystron	5 stage ESCIOT
HVDC Power	366.0 kW	103.3 kW
Cabinets	13.0 kW	13.0 kW
Cooling System	30.0 kW	8.4 kW
Total Transmitter Plant	409.0 kW	124.7 kW
Annual Power cost	\$286,627	\$87,390
Annual Savings	0	<b>\$199,237</b>

Chart 3 assumes that the klystron transmitter is operating in a non-pulsed mode. If pulsing is in use, the savings would still exceed \$125,000 per annum in the above example.

### DUAL USE TRANSMITTERS

We have discussed perhaps the most costly component of the high power transmitter in some detail above – particularly in relation to minimizing the difference between analog and digital service. What of the other critical components? Exciters are now available from Ai and others that require only the exchange of one module to convert from analog to digital service. Further, these exciters can be set to any UHF channel via the front panel interface without the need to change any components or tune RF circuits. The IOT driver amplifiers should be broadband, allowing operation on any UHF channel.

The high power RF system is unique to the specific TV channel and transmitter configuration. A change in channel will almost certainly mean a change in these major components. However, there is a distinct possibility that some broadcasters, particularly those out of the core channels, may elect to switch to their existing analog channel at the conclusion of the transition. We have already seen that it is entirely feasible to provide a highly efficient analog transmitter that can produce a digital signal, also highly efficiently, with the swap of a module. The final step in the goal of true dual-use equipment, at least for the above broadcasters, would be the supply of a DTV Mask filter with the new analog transmitter. A conventional DTV Mask filter is perfectly acceptable for NTSC signals. The same cannot be said for Sharp-tuned filters since such filters actually cut off the edges of the NTSC pass band.

### CONCLUSION

When one considers that the NTSC signal will probably remain a TV station's main source of revenue for years to come, the above article shows that there is definite reason to consider replacing aging high power UHF transmitters now. Recent changes in the tax law, favoring capital investment, may indeed add to the power savings in providing bottom line benefits for the station and its owners.

Modern, water-cooled ESCIOT equipped transmitters offer many broadcasters immediate benefits in either digital or analog service and provide maximum flexibility for future conversion to DTV service.

### ACKNOWLEDGEMENTS

The authors wish to thank their colleagues at Ai for contributions to this paper. Sound technical input was received from the engineering staff of e2v technologies.

### REFERENCES

1. Steve Aitken and Greg Morton, « Depressed Collector IOTs: Proven Digital Performers --- But What of Analog?. » e2v technologies 2003. Attached as an Appendix to this paper.